

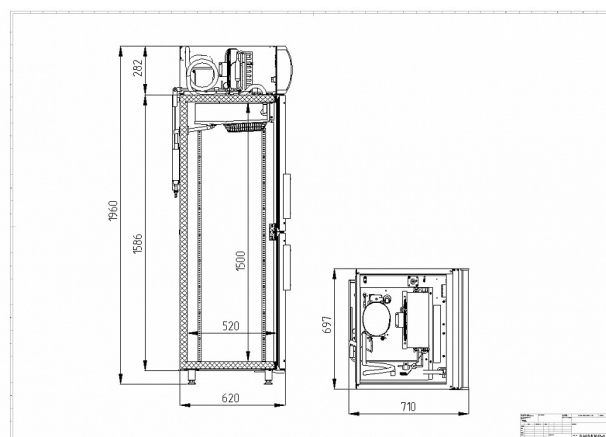

## DB105hd-S

Recommended retail price: 156 500 rub

The unique cabinet for frozen food and ice cream, thanks to access to the contents through two doors in a single volume with double-glazed windows, preserves the temperature of the food to the maximum even with frequent opening of the doors, saves energy, makes the work of the staff easier and more comfortable.



### Technical specifications

Volume, l:	500
Environmental conditions (t, °C / humidity, %):	up to +25 / up to 60
Dimensions:	697x710x1960
Case wall thickness, mm:	43
Unit location:	upper position
Temperature range, °C:	-21...-18
Volume, l:	500
Power supply system, V/Hz:	230/50
Daily power consumption, kW/h, max:	10
Cooling type:	dynamic
Refrigerant:	R290
Defrost type:	automatic heaters with condensate evaporation system

Thermostat:	electronic control unit
Shelf size, mm:	595x455
Load capacity per shelf, kg:	40
Number of shelves:	4
Backlight:	upright
Material of the exterior cladding:	Painted galvanized steel
Door type:	Glass hinged
Series of cabinets:	SmartDoor
Number of doorway frames:	2
Cabinet type:	Low temperature

The manufacturer reserves the right to make changes that do not fundamentally affect the operational properties of the equipment without prior notice.