

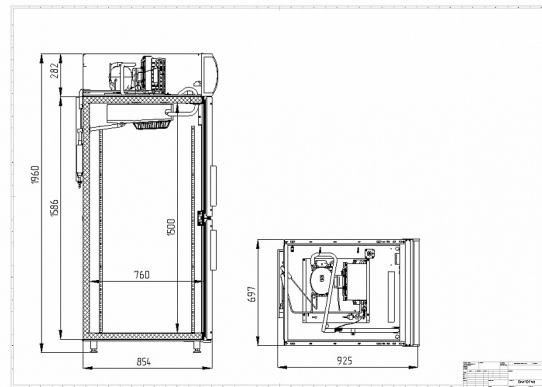

## DM107hd-S without canap?s

The convenient and practical cabinet provides access to products in a single refrigerated volume through two doors with double-glazed windows in aluminum frames. The shelves comply with the Gastronorm standard.



### Technical specifications

Volume, l:	700
Environmental conditions (t, °C / humidity, %):	up to +32 / up to 60
Dimensions:	697x945x1960
Case wall thickness, mm:	43
Unit location:	upper position
Temperature range, °C:	+1...+10
Volume, l:	700
Power supply system, V/Hz:	230/50
Power consumption, W, max.:	400
Daily power consumption, kW/h, max:	4
Cooling type:	dynamic
Refrigerant:	R290
Defrost type:	automatic with condensate evaporation system
Thermostat:	electronic control unit
Shelf size, mm:	530x650

Load capacity per shelf, kg:	40
Number of shelves:	4
Backlight:	LED
Material of the exterior cladding:	Painted galvanized steel
Door type:	Glass hinged
Series of cabinets:	SmartDoor
Number of doorway frames:	2
Cabinet type:	Medium temperature

The manufacturer reserves the right to make changes that do not fundamentally affect the operational properties of the equipment without prior notice.